

AFTERCARE INSTRUCTIONS

Your fitting has a high quality finish and should be treated with care to preserve the visible surfaces.

All surface finishes will wear if not cleaned correctly, the only safe way to clean your mixer is to wipe with a soft damp cloth. Stains can be removed using washing up liquid. All bath cleaning powders and liquids will damage the surface of your fitting, even the non-scratch cleaners.

GUARANTEE

All products are manufactured to the highest standards and a 5 year guarantee covers any defect in manufacture.

NOTE: The 5-year guarantee on the cartridge is invalidated if damaged by any waterborne debris.

In the interests of continuous product development we reserve the right to alter specification as necessary

PRODUCT CODE:

PLEASE ENTER YOUR PRODUCT CODE ABOVE IN THE BOX PROVIDED, WHICH WILL BE REQUIRED FOR ANY FUTURE CORRESPONDENCE REGARDING THIS PRODUCT

PRODUCT IDENTIFICATION CODE LASER ETCHED ON PRODUCT

Installer please fill in code here _____.

TELEPHONE HELPLINE! +44 (0)844 701 6273

Bristan Group Limited
Birch Coppice Business Park
Dordon
Tamworth
Staffordshire
B78 1SG
UK

A Masco Company

Website: www.bristan.com

Telephone: +44 (0) 844 701 6274

Facsimile: +44 (0) 844 701 6275

(FI PM VSHXSP)

(Rev.D3)

BRISTAN

Prism Inline Vertical Shower Pole

(With Integral Diverter to Handset or With Fixed Head)

Fitting Instructions



Before starting any installation project, consider 'safety' first. Look for the 'safety note' and read the safety advice.

Please keep these instructions for future reference and request of replacement part

CONTENTS

Section	Description	Page No:
1.	Introduction	2
2.	Specification	2
3.	Pack Contents Checklist	2
4.	Installation	5
5.	Operation	9
6.	Setting	9
7.	General Fault Diagnosis	11
8.	Cleaning & Maintenance	11
9.	Guarantee & Registration	12
10.	Notes	13

NOTES:

NOTES:

1. Introduction

Your Bristan dual control shower fitting is a thermostatic mixer incorporating a wax capsule thermostat to ensure constant showering temperatures.

This valve has been designed to comply with BS EN 1287:1999 & BS EN1111:1999. Manufactured to the highest quality standards.

These instructions are for your guidance to a safe and successful installation and should be left with the user.

All products manufactured and supplied by Bristan are safe provided they are installed, used correctly and receive regular maintenance in accordance with these instructions.

2. Specification

Water Pressures: Min. 0.5 bar, Max. 5 bar (PM VSHXSP)

Min. 1.0 bar, Max. 5 bar (PM VSHXSPDIV)

Maximum recommended imbalance between hot and cold supply should not exceed a ratio of 5:1.

Maximum Outlet Temp: Factory Set to 38°C to the temperature stop (can be re-set to suit site conditions).

Hot & Cold Supply Temperature

Maximum Cold supply: 25°C

Minimum recommended hot supply: 60°C

Maximum Hot Supply: 80°C

Note: the inlet hot water temperature must be at least 10°C above the required blend temperature.

3. Pack Contents Check List

PM VSHXSPDIV	PM VSHXSP
1 x Shower Valve	1 x Shower Valve
1 x Shower Valve Fixing Pack	1 x Shower Valve Fixing Pack
1 x Plastering Shroud	1 x Plastering Shroud
1 x Shower Pole With Diverter	1 x Shower Pole
1 x Shower Rose	1 x Shower Rose
1 x Shower Pole Fixing	1 x Shower Pole Fixing
1 x Handset	
1 x Parking Station	
1 x Shower Hose	

7. Fault Diagnosis

If your valve fails to function correctly, the following should be checked:

7.1 Check that the hot and cold connections are the correct way around. Hot to the upper inlet and cold to the lower.

7.2 Ensure that the hot water temperature is adequate. The recommended minimum hot water temperature is 60°C. The hot water temperature should be at least 10°C higher than the required blend temperature to ensure that the safety shut off will work

7.3 If your shower will not turn off:

7.3.1 Check ceramic disc valve (19) is free of debris and undamaged.

7.4 If your shower has a low flow rate.

7.4.1 Check that the filters (10) are not blocked.

8. Cleaning & Maintenance

8.1 Cleaning

Your fitting has a high quality finish and should be treated with care to preserve the visible surfaces.

All surface finishes will wear if not cleaned correctly, the only safe way to clean your mixer is to wipe with a soft damp cloth. Stains can be removed using washing up liquid. All bath cleaning powders and liquids will damage the surface of your fitting, even the non-scratch cleaners.

8.2 Regular Maintenance (See Fig.8)

We advise that the valve is regularly serviced, particularly in hard water areas. It is also important to clean the rose and handset regularly in hard water areas to maintain an even spray/flow of water.

NOTE: ISOLATE THE WATER SUPPLY TO THE SHOWER VALVE.

8.3 Cartridge Removal

8.3.1 Remove the handle cap (18) and unscrew the grub screw (17), then remove temperature control handle (16) and temperature stop (15).

8.3.2 Unscrew the cartridge (14) anticlockwise out of the body.

8.4 Cartridge Maintenance

8.4.1 Place the cartridge in a bowl and carefully add some hot water (just off the boil) and vinegar to de-scale the cartridge. Leave until the water has cooled.

8.4.2 Then remove the cartridge and rinse with clean water.

8.5 Refitting the Cartridge

8.5.1 Grease the seals with suitable silicon grease and carefully refit the cartridge into

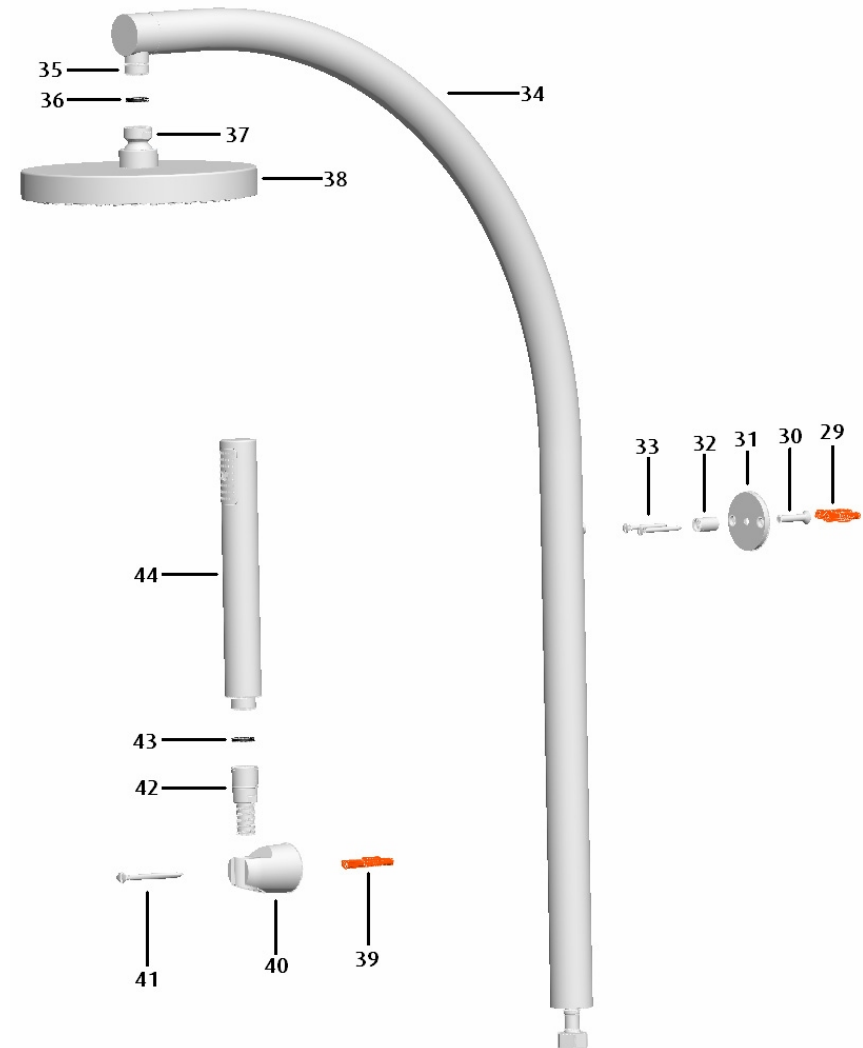

Fig. 2

4. Installation

4.1 Pre-Installation (See Fig.1 & 2)

4.1.1 Identify all components and check for completeness, particularly before arranging fitting.

4.1.2 This mixer should be installed in compliance with Water Regulations. For further details contact your Local Water Authority.

4.1.3 This mixing valve is suitable for use with the following systems:

Gravity Fed Hot & Cold (Equal Pressure) PM VSHXSP only.

Gravity Fed Hot & Mains Cold (Differential Pressure 5:1 Max.) PM VSHXSP only.

Un-vented Systems

Thermal Store Systems

Gas Combination Boiler

Pumped System

PLEASE NOTE:

On gravity systems the minimum distance from the underside of the cold-water storage tank to the showerhead must be at least 5metres for PMVSHXSP and at least 10 metres for PM VSHXSPDIV.



Before starting any installation project please consider:

Prior to drilling into walls, check there are no hidden electrical wires, cables or water supply pipes with the aid of an electronic detector. If you use power tools do not forget:

- Wear eye protection
- Unplug equipment after use

4.2 Installation (See Fig. 1,2,3,4,5 & 6)

NOTE - If you have no or limited rear access, go to 4.2.1, if you have rear access go to 4.2.2.

4.2.1 With no rear access valve body installation (both valves).

4.2.1.1 Determine correct orientation and required position for the valve and arrange the pipe work to suit. Pipe work must be secure and unable to move in and out of the wall.

Ensure Hot supply feeds upper inlet, and Cold feeds lower inlet as shown (see Fig.1, page 3).

4.2.1.2 Cut both hot and cold inlet pipes, flush with where the tiled wall surface will be, ensure any burrs are removed.

IMPORTANT - THIS MUST BE ACCURATE, FAILURE TO DO SO COULD MEAN BACKPLATE WILL NOT FIT FLUSH TO THE WALL.

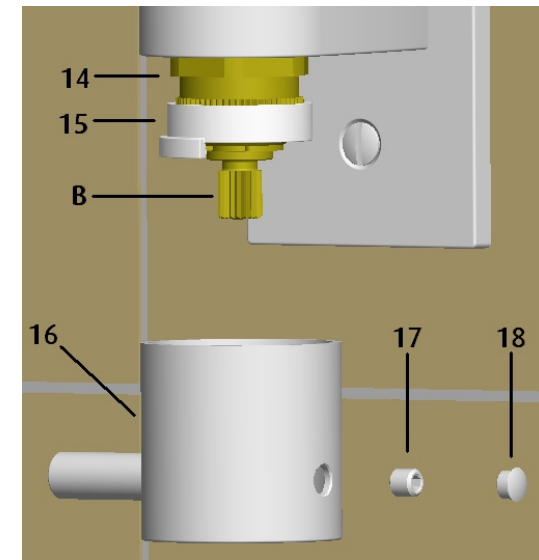
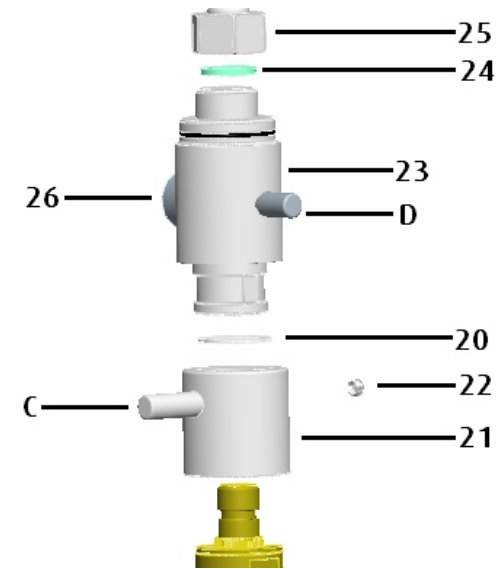

Fig.8

4.3.6 Connect the shower hose (28) (cylindrical end) to the diverter connection (26) ensuring that the washer (27) is fitted. Connect the other end (42, Conical) of the hose to the handset (44) ensuring that the washer (43) is fitted.

5. Operation (See Fig.1, 2 & 7)

5.1 Operation of the PM VSHXSP

5.1.1 There are 2 handles on this valve. The upper handle operates the on/off and flow, the lower handle is the temperature control. The arrows on the handle indicate the direction for hot and cold adjustment.

5.1.2 To increase the temperature past the 38°C safety stop press in the lever (A) on the temperature handle and carry on turning past the stop, once past this point the lever does not need to be held in. Once past the safety stop the handle will come to a final stop position.

5.2 Operation of the PM VSHXSPDIV

5.2.1 There are 2 handles on this valve. The upper handle operates the on/off and flow, the lower handle is the temperature control. The arrows on the handle indicate the direction for hot and cold adjustment.

5.2.2 To increase the temperature past the 38°C safety stop press in the lever (A) on the temperature handle and carry on turning past the stop, once past this point the lever does not need to be held in. Once past the safety stop the handle will come to a final stop position.

5.2.3 To divert the flow of water from the overhead shower rose (38) to the handset (44) pull the peg (D) on the diverter whilst the shower is running. To divert back push the peg back in. If the shower is turned off without being diverted back, the diverter will automatically return back to the overhead shower rose position.

6. Setting (see Fig. 8, Over leaf)

The temperature stop is factory set at 38°C. This can be overridden by pushing in the peg and turning past the factory setting. This can be adjusted further for site conditions or personal preference by: remove the handle cap (18) and the loosen the grub screw (17), remove the temperature control handle (16) and turn the control spindle (B) in the required direction to increase or decrease the temperature. Replace the handle at the temperature stop (15) max. position and check the valve functions correctly from cold to hot.

4.2.1.3 Use plastering shroud (45) as a guide to finish wall (see Fig.3 below). The shroud will also assist in maintaining required pipe centres of 44mm.



4.2.1.4 Drill 2 x holes in finished wall to suit wall plugs supplied (if required or a suitable alternative wall plug) at 110mm centres taking care to avoid pipe work. Insert wall plugs (1) as necessary.

4.2.1.5 Remove plastering shroud (45).

IMPORTANT - DO NOT FIT BACKPLATE UNTIL YOU HAVE RE-CHECKED PIPES ARE FLUSH WITH TILED WALL SURFACE AND NOT PROUD OF THE WALL. PLATE CANNOT BE REMOVED EASILY ONCE FITTED! If the pipes are proud then they must be shortened.

Carefully slide back plate (2) over pipe work. Between 15 – 23mm of the pipe needs to locate within the back plate to ensure a seal (measured from the back). If in doubt remove brass inserts (9) by unscrewing anti-clockwise, if both o-rings (6&8) are located around the pipe then all is fine (see Fig.4, Page 8). Carefully screw brass insert back into back plate (see Fig.5, Page 8).

4.2.1.6 Secure back plate to wall using screws (3).

4.2.1.7 Push shower body (12) onto back plate (outlet pointing up) and secure using grub screws (13) and hexagon key as shown in Fig.6, page 8.

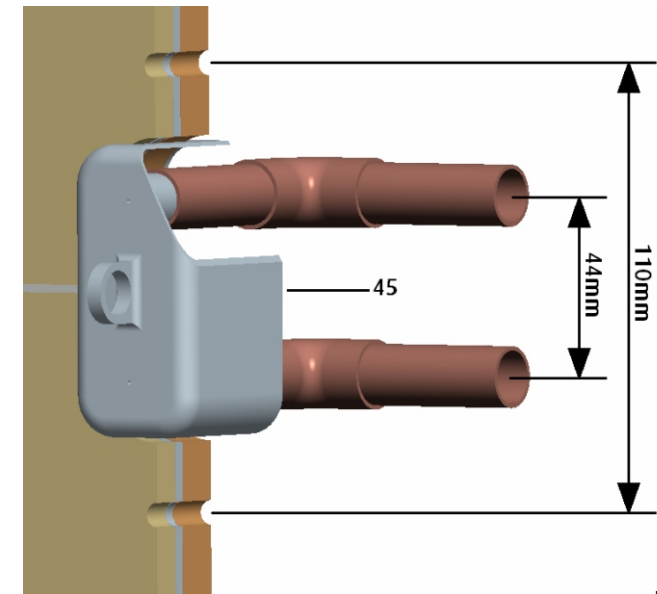

Fig. 3

4.2.2 With rear access valve body installation (both valves) (See Fig.1, 2, 3, 4, 5 & 6).

4.2.2.1 Cut two pieces of pipe long enough to go through the wall and to meet pipe work. Between 15-23mm of pipe needs to locate within back plate to ensure a seal. Locate the two pipes into the brass inserts (9) on the back plate (2).

Ensure Hot supply feeds upper inlet, and Cold feeds lower inlet as shown.

4.2.2.2 Determine correct orientation and required position for the valve.

4.2.2.3 Use plastering shroud (45) as a guide to finish wall. The shroud will also assist in maintaining the required pipe centres off 44mm.



4.2.2.4 Drill 2 x holes in finished wall to suit wall plugs supplied (if required) at 110mm centres taking care to avoid pipe work. Insert wall plugs (1) as necessary.

4.2.2.5 Remove plastering shroud. Secure backplate to wall using screws (3) (see Fig 4 overleaf).

4.2.2.6 Connect pipes to pipe work.

4.2.2.7 Push shower body (12) onto back plate (outlet pointing up) and secure using grub screws (13) and hexagon key as shown in Fig. 4.

4.3 Fitting the Shower Pole (See Fig.1 & 2 Pages 3 & 4).

4.3.1 Fit the wall plate (31) and bridge (32) with the screw (30) to the shower pole.

4.3.2 Connect the shower pole flexible connection (25) to the spacer/diverter (23) with the washer (24). (For the PM VSHXDIV model ensure that the diverter will be parallel with the fixing plate (31) on the pole without the flexible hose 25 being twisted).

4.3.3 Push the spacer/diverter (23) into the flow control handle (21) locating onto the valve (19) ensuring that the slip washer (20) fits between the head (21) and the spacer/diverter (23).



4.3.4 Mark the position of the holes in the shower poles fixing plate (31), remove the shower pole from the shower, and drill 2 x holes in finished wall to suit wall plugs (29) supplied (if required), fit the wall plugs (29) to the holes, and refit the shower pole assembly to the shower and secure the pole to the wall with the supplied screws (33).

4.3.4 Fit the rose (38) to the pole connection (35) ensuring that the black rubber washer (36) is used.

Shower Pole with integral Diverter Only (See Fig.1 & 2 Pages 3 & 4).



4.3.5 Position the parking station (40) on the wall in a suitable location ensuring that there are no hidden pipe's or electrical cables in the wall and that the handset (44) will reach the parking station (40). mark the locations of the fixing holes onto the wall and drill 2 x holes in finished wall to suit wall plugs (39) supplied (if required), fit the wall plugs (29) to the holes and screw the parking station (40) to the wall using the screws (41) supplied.

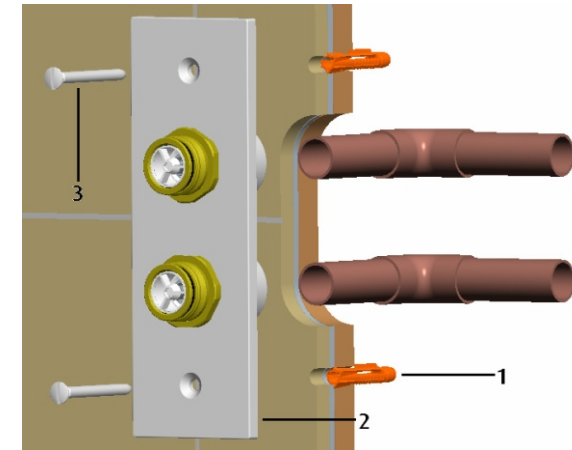

Fig. 4

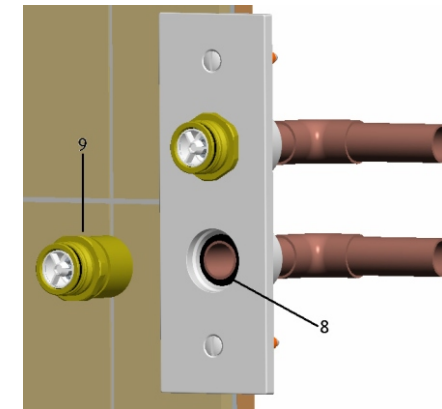

Fig. 5

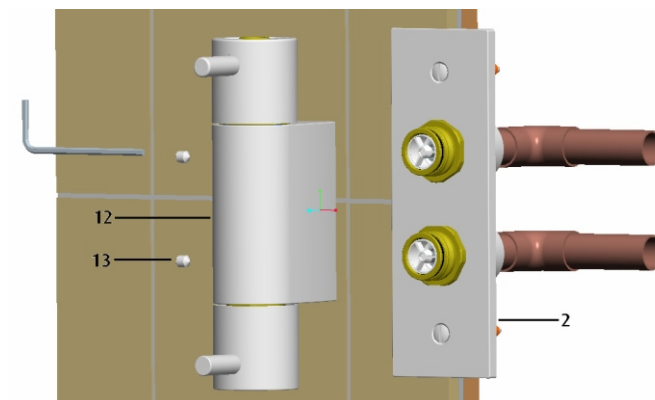

Fig. 6