

MAINTENANCE

If any of the fittings begin to drip:

1. Turn off the water supply.
2. Remove cap (3) and grub screw (2), and then remove handle (1) by pulling from shroud (4). Unscrew the shroud (4) and cartridge retaining ring (5). Then remove the cartridge (6).
3. Once removed, carefully clean seating, rubber washer and ceramic disc.
4. Replace all of the above then turn on the water supply.
5. If problem persists contact our helpline quoting the product code.

AFTERCARE INSTRUCTIONS

Your fitting has a high quality finish and should be treated with care to preserve the visible surfaces. All surface finishes will wear if not cleaned correctly, the only safe way to clean your mixer is to wipe with a soft damp cloth. Stains can be removed using washing up liquid. All bath cleaning powders and liquids will damage the surface of your fitting - even non-scratch cleaners.

Please Note: In the unlikely event you find a part missing please contact our Customer Service Helpline on 0844 701 6273 or email enquire@bristan.com for immediate despatch of part.

GUARANTEE

All products are manufactured to the highest standards and a 5 year guarantee covers any defect in manufacture.

NOTE: The 5 year guarantee on the valves is invalidated if damaged by any waterborne debris.

In the interests of continuous product development we reserve the right to alter specification as necessary.

PRODUCT CODES: JS2 1HBF C, JS2 BAS C, JS2 TBAS C, JS2 BASNW C, JS2 BID C, JS2 WMBAS C & JS2 WMBF C

TELEPHONE HELP LINE: 0844 701 6273

Bristan Group Ltd
Birch Coppice Business Park
Dordon
Tamworth
Staffordshire
B78 1SG
UK
A Masco Company

Web Site: www.bristan.com
Telephone: 0844 701 6274
Facsimile: 0844 701 6275
Email: enquire@bristan.com

BRISTAN

JS2 Range

Fitting Instructions



Before starting any installation project, consider 'safety' first. Look for the 'safety note' and read the safety advice.

Please leave these instructions with the user.

WATER PRESSURE

These taps are suitable for use at all supply pressures. If installed at low pressure (tank fed), then the minimum distance from the outlet of the nozzle to the underside of the cold tank should be approximately 2 metres (0.2 bar), unless otherwise stated, to ensure adequate performance. The taps should be installed in compliance with Water Regulations. For further details contact your Local Water Authority.

1 HOLE BATH FILLER

1. Identify all components and check for completeness, particularly before arranging fitting.
2. Fit the mixer body (7) to the bath using the plinth (8) above and the fixing kit (9) below the surface. The full rubber washer goes between the fitting and the bath, and the 'C' shaped rubber and metal washers on the underside of the bath, to be secured by the nut and threaded rod.
3. Fit the tail pipes (10) to the fitting **by hand only** and then connect the hot and cold supplies.
4. Fully open the mixers in the mid position, letting it run for a few minutes to check all connections for leaks.
5. See the back page for aftercare instructions.

CONTENTS

1. Handle
2. Grub Screw
3. Cap
4. Shroud
5. Cartridge retaining ring
6. Cartridge
7. Body
8. Plinth & Washer
9. Fixing Kit
10. Tail Pipes

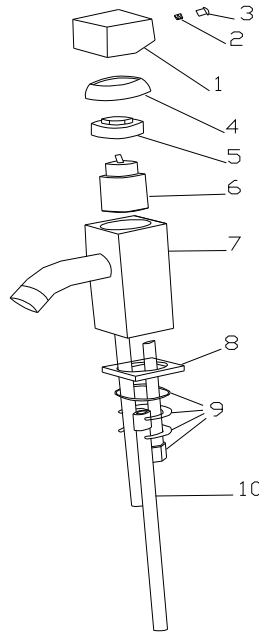

BIDET MIXER AND BASIN MIXER WITH / WITHOUT WASTE

1. Identify all components and check for completeness, particularly before arranging fitting.
2. Install the body (7) to the basin. Secure the body (7) to the surface using the fixing kit (9) with plinth washer (8) above the basin and the fixing kit (9) below.
3. Screw in connecting copper tail pipes (10) by hand and then connect the hot and cold water supplies.
4. If applicable fit the pop up waste (11) with the flat washer below and the shaped washer above the basin. It is advised that a silicon sealant be applied to both sealing faces of washers. The plug height can be set by adjusting the waste operating rod (13), rod connector (12) and the screw in the base of the plug. Friction for the waste mechanism can be adjusted using the waste cap.
5. Turn on the water supplies. Lift and turn handle both ways for a few minutes letting the water flow, to check all joints and connections for leaks.
6. See the back page for aftercare instructions.

CONTENTS

1. Handle
2. Grub Screw
3. Cap
4. Shroud
5. Cartridge retaining ring
6. Cartridge
7. Body
8. Plinth & Washer
9. Fixing Kit
10. Tail Pipes
11. Waste (If applicable)
12. Pop Up Connector (If applicable)
13. Pop Up Rod (If applicable)

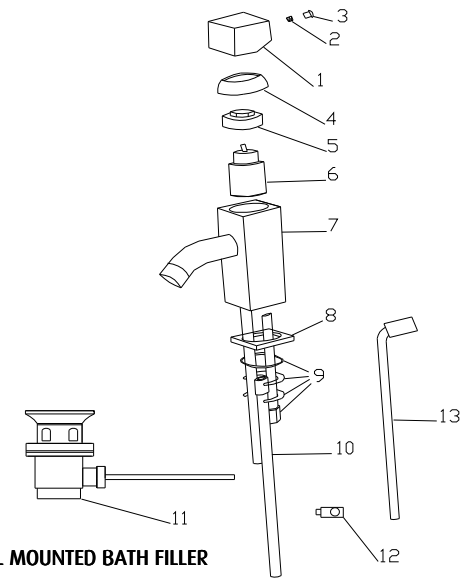

WALL MOUNTED BASIN MIXER AND WALL MOUNTED BATH FILLER

1. Identify all components and check for completeness, particularly before arranging fitting.
2. Decide on the final position of the body (7). A baton within the wall structure may be required to ensure the depth is achieved to ensure the concealing plate fits correctly.

Prior to drilling into walls, check there are no hidden electrical wires, cables or water supply pipes with the aid of an electronic detector. If you use power tools do not forget to:

- Wear eye protection
- Unplug equipment after use



3. Plumb up the hot and cold supply pipes to the required position.
4. Set fitting into wall, and then attach pipework to the hot and cold inlets using the nuts and olives (17).
5. Secure mixer body (7) using the screws and wall plugs from the fixing kit (9). It is important that the spout (15) is not damaged and that sufficient thread is left exposed to allow the spout and shroud connectors to fit.
6. Please note, before finishing wall turn on water supplies to check both correct mixer function and for leaking from connections. Complete the wall finish allowing access to body assembly.
7. Fit the spout (15) ensuring all parts are assembled in order. Use suitable sealant to secure and seal plates.
8. Attach handles (1) by pushing on to the cartridge (6).
9. See over the page for aftercare instruction

CONTENTS

1. Handle
2. Grub Screw
3. Cap
4. Shroud
5. Cartridge retaining ring
6. Cartridge
7. Body
14. Body Shroud
15. Spout
16. Concealing plate
17. Nuts and Olives

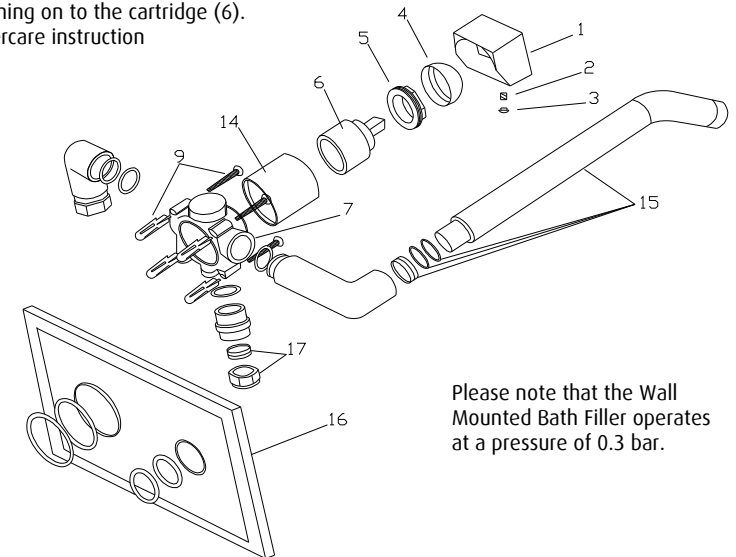

Please note that the Wall Mounted Bath Filler operates at a pressure of 0.3 bar.